



## VM Pump Co. – Bronze Pumps



<u>Part Number</u>	<u>Description</u>	<u>List Price</u>
9402-9803	5VMB-S2 5HP CAST BRONZE 230V	\$10,368.00
9402-9804	5VMB-T 5HP CAST BRONZE 208-230/460V	\$9,676.80
9402-9805	5VMB-T5 5HP CAST BRONZE 575V	\$9,676.80
9402-8057	75VMB-S2 7.5HP CAST BRONZE 230V	\$11,520.00
9402-9774	75VMB-T 7.5HP CAST BRONZE 208-230/460V	\$10,368.00
9402-9758	75VMB-T5 7.5HP CAST BRONZE 575V	\$10,368.00
9402-8020	10VMB-S2 10HP CAST BRONZE 230V	\$12,672.00
9402-8016	10-VMB-T 10HP CAST BRONZE 208-230/460V	\$11,059.20
9402-8008	10VMB-T5 10HP CAST BRONZE Pump 575V	\$11,059.20

## VM Pump Co. – Cast Iron Pumps



<u>Part Number</u>	<u>Description</u>	<u>List Price</u>
9402-9956	5VMC-S2 5HP CAST IRON 230V	\$7,833.60
9402-9972	5VMC-T 5HP CAST IRON 208-230/460V	\$6,912.00
9402-9998	5VMC-T5 5HP CAST IRON 575V	\$6,912.00
9402-8065	75VMC-S2 7.5HP CAST IRON 230V	\$8,524.80
9402-9782	75VMC-T 7.5HP CAST IRON 208-230/460V	\$7,488.00
9402-9766	75VMC-T5 7.5HP CAST IRON 575V	\$7,488.00
9402-8041	10VMC-S2 10HP CAST IRON 230V	\$9,216.00
9402-8040	10-VMC-T 10HP CAST IRON 208-230/460V	\$8,179.20
9402-8032	10VMC-T5 10HP CAST IRON 575V	\$8,179.20



VM Pump - Parts

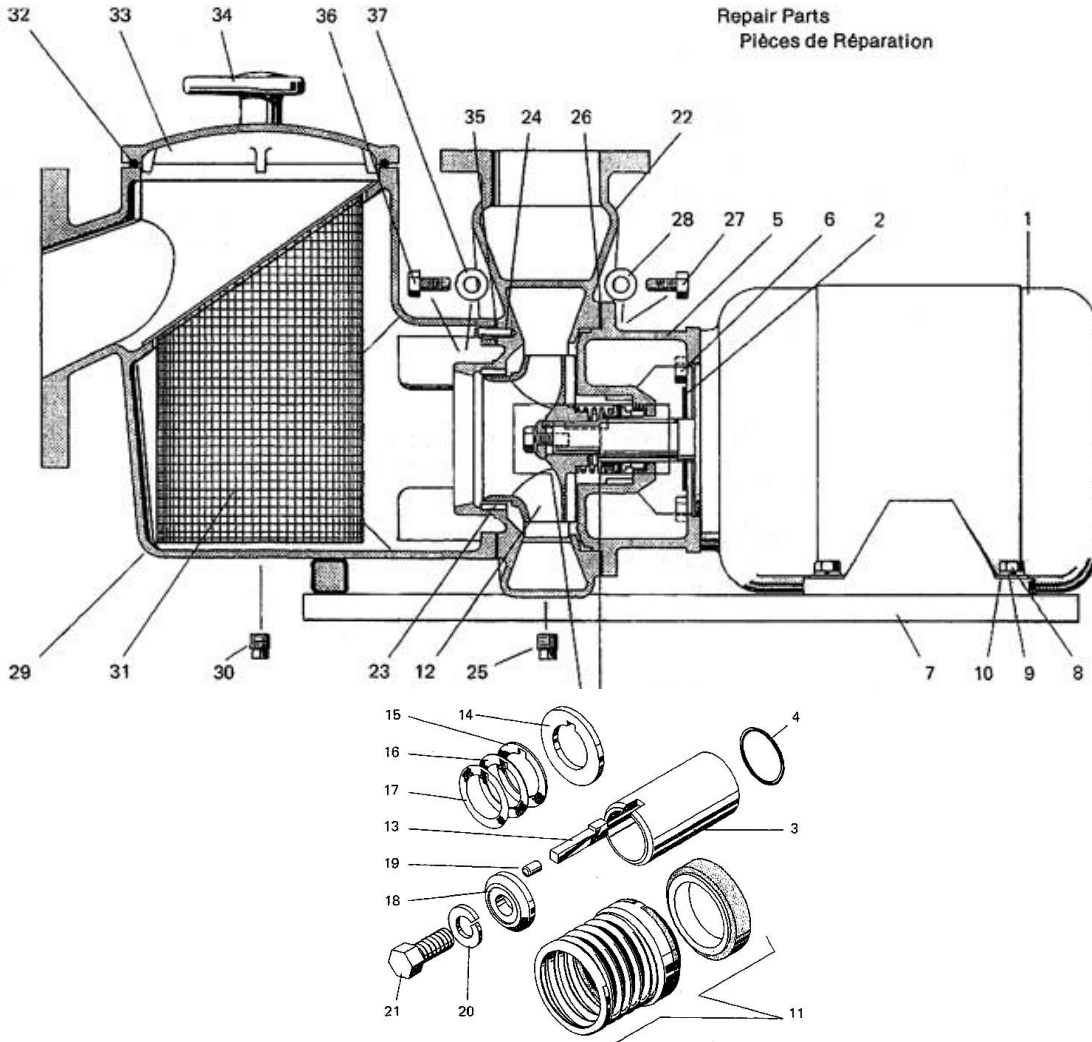

<u>Part Number</u>	<u>Description</u>	<u>List Price</u>
9017-9235	#1 - 5 HP VM 1/60/230, 184JM MOTOR	\$1,932.25
9017-9243	#1 - 5 HP VM 3/60/208-230/460,182JM MOTOR	\$1,604.75
9017-9250	#1 - 5 HP VM 3/60/575, 182JM MOTOR	\$1,604.75
9010-8697	#1- 7.5 HP VM 1/60/230, 213TCZ MOTOR	\$3,301.20
9017-9268	#1 - 7.5 HP VM 3/60/208-230/460, 184JM MOTOR	\$1,777.67
9017-9276	#1 - 7.5 HP VM 3/60/575, 184JM MOTOR	\$1,777.67
9017-9723	#1 - 10 HP VM 1/60/230, 215TCZ MOTOR	\$4,597.92
9017-9722	#1 - 10 HP VM 3/60/208-230/460,213TCZ MOTOR	\$2,491.20
9010-9844	#1 - 10 HP VM 3/60/575, 213TCZ MOTOR	\$2,491.20
22-0727-06	#2 - FLINGER	\$15.26
02-2500-09	#5 - 5VMC-S2, T, T5 & 7.5VMC-T, T5- BRACKET	\$540.00
02-2500-17	#5 - 5 VMB-S2, T, T5 & 75VMB-T, T5- BRACKET	\$777.60
02-2510-07	#5 - 7.5VMC-S2, 10VMC-S2, T, T5- BRACKET	\$1,164.96
02-2510-15	#5 - 7.5VMB-S2, 10VMB-S2, T, T5- BRACKET	\$1,771.20



## VM Pump - Parts



<u>Part Number</u>	<u>Description</u>	<u>List Price</u>
14-1293-24	Hex Cap Screw 3/8-16 x 7/8"L - 5 & 7.5VM - 4pack - #6 in diagram	\$7.20
14-1330-29	Hex Cap Screw 1/2-13 x 1 1/4"L - 10VM - 4pack - #6 in diagram	\$12.67
08-0328-07	7.5VMC/B-S2 & 10VMC/B-S2, T, T5 - SLEEVE - #3 in diagram	\$289.44
08-1000-00	5VMC/B-S2, T, T5 & 7.5VMC/B-T, T5 - SLEEVE - #3 in diagram	\$264.96
47-0022-09	O-Ring 1" x 1-1/8" #4 in diagram	\$2.30
10-0369-03	Mechanical Seal Assy. #11 in diagram	\$115.78
14-0219-01	Washer #10 in diagram	\$48.24
14-2055-04	Shim x .031 #15 in diagram	\$21.46
14-2055-12	Shim x .020 #16 in diagram	\$21.46
14-2055-20	Shim x .010 #17 in diagram	\$21.46
05-8009-09	5VMC - IMPELLER - #12 in diagram	\$630.72
05-8009-17	5VMB - - IMPELLER - #12 in diagram	\$786.24
05-8010-06	7.5VMC-T, T5 - IMPELLER - #12 in diagram	\$704.16
05-8010-14	7.5VMB-T, T5 - IMPELLER - #12 in diagram	\$830.88
05-8045-05	7.5VMC-S2 - IMPELLER - #12 in diagram	\$704.16
05-8045-13	7.5VMB-S2 - IMPELLER - #12 in diagram	\$830.88
05-8046-04	10VMC - IMPELLER - #12 in diagram	\$704.16
05-8046-12	10VMB - IMPELLER - #12 in diagram	\$830.88
14-0504-13	Adaptor - #18 in diagram	\$72.72
14-0382-10	Dowel Pin - #19 in diagram	\$16.14
22-0559-09	Gib Key - #13 in diagram	\$27.79
14-0722-01	Washer - #14 in diagram	\$1.87
14-2493-04	Cap Screw 3/8-16 x 1"L - #21 in diagram	\$8.52
03-1906-00	Case w/Wear Ring & Plug: VMC - #22 in diagram	\$1,476.00
03-1906-18	Case w/Wear Ring & Plug: VMB - #22 in diagram	\$3,312.00
08-1001-09	Wear Ring - #23 in diagram	\$205.92
31-0059-11	Plug 1/4"NPT - Galvanized VMC - #25 in diagram	\$2.74
31-0059-29	Plug 1/4"NPT - Brass VMB - #25 in diagram	\$5.32
13-0191-04	Gasket - #26 in diagram	\$19.30
14-2015-03	Index Pin - #24 in diagram	\$16.42
13-1223-04	Gasket - #26 in diagram	\$15.55
39-0647-04	Strainer Body: VMC - #29 in diagram	\$1,476.00
39-0647-12	Strainer Body: VMB - #29 in diagram	\$3,168.00
14-0005-09	Grommet - 8/pkg - #28 in diagram	\$40.32
14-1293-16	Hex Cap Screw 3/8-16 x 7/8"L: VMB 8/pkg - #27 in diagram	\$12.96
14-1293-24	Hex Cap Screw 3/8-16 x 7/8"L: VMC 8/pkg - #27 in diagram	\$7.34



16-0707-08	Strainer basket - #31 in diagram	\$630.72
39-0648-03	Strainer Cover: VMC - #33 in diagram	\$185.76
39-0648-11	Strainer Cover: VMB - #33 in diagram	\$437.76
31-0059-11	Plug 1/4"NPT - Galvanized VMC - #30 in diagram	\$2.74
31-0059-29	Plug 1/4"NPT - Brass VMB - #30 in diagram	\$5.32
47-0442-01	O-Ring 7-1/4" x 7-3/4"- #32 in diagram	\$19.32
39-0646-05	Lock Knob Assy. - 2 / Pkg - #34 in diagram	\$81.65
12-0618-00	Base: 5VM, 7.5VM-T - #7 in diagram	\$185.76
12-0618-18	Base: 7.5VM-S2, 10VM - #7 in diagram	\$334.08
14-1294-23	Hex Cap Screw 3/8-16 x 1"L - 4 / Pkg #8 in diagram	\$7.20
14-0722-19	Washer 3/8" - 4 / Pkg - #10 in diagram	\$3.74
KIT-SS	Assy. Kit Includes 3"&4" Flanges and Gaskets. Stainless Steel Bolts, Nuts & Washers.	\$295.20
KIT-ZN	Assy. Kit Includes 3"&4" Flanges and Gaskets. Zinc Bolts, Nuts & Washers.	\$218.88

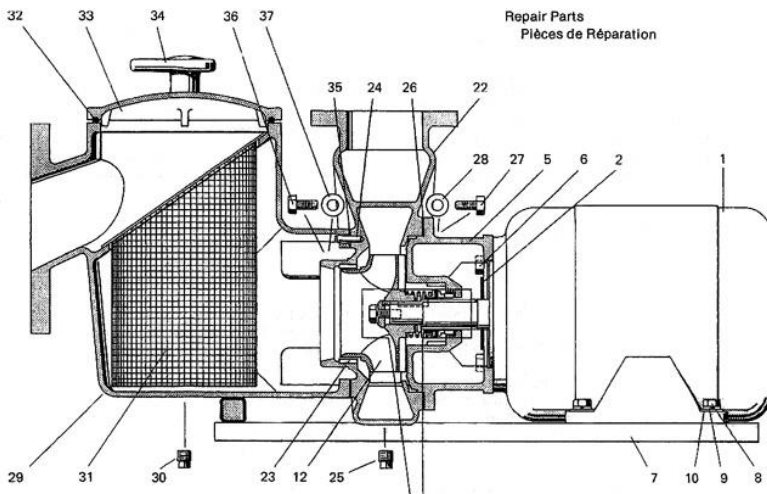

Repair Parts  
Pièces de Réparation

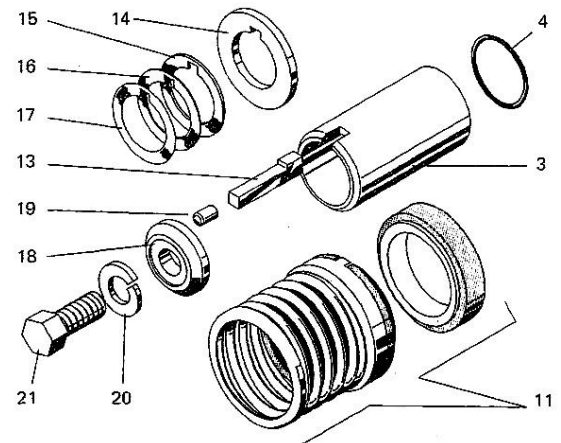

See exploded view at right for identification of parts enclosed in rectangle.  
Voir gros plan à droite pour identifier les pièces renfermées dans le rectangle.



## Speck Pumps – EcoVariable Frequency Drive Pumps



<u>Part Number</u>	<u>Description</u>	<u>List Price</u>
2043136206	1HP BADU EcoM2/433-II SF1.0 2SPD	\$1,632.16
2043136209	1HP BADU EcoM2/433-II SF1.0 2SPD	\$2,066.21
2043156206	1.5HP BADU EcoM2/433-III SF1.0	\$1,652.97
2043156209	1.5HP BADU EcoM2/433-III SF1.0	\$2,104.86
2043216206	2HP BADU EcoM2/433-IV SF1.0	\$1,740.67
2043216209	2HP BADU EcoM2/433-IV SF1.0	\$2,216.35
2043266206	2.5HP BADU EcoM2/433-V SF1.0	\$1,782.30
2043266209	2.5HP BADU EcoM2/433-V SF1.0	\$2,339.73
2072216206	2HP BADU EcoM2/72-IV SF1.0 2SPD	\$1,575.67
2072216209	2HP BADU EcoM2/72-IV SF1.0 2SPD	\$2,133.11
2072266206	2.5HP BADU EcoM2/72-V SF1.0 2SPD	\$1,654.46
2072266209	2.5HP BADU EcoM2/72-V SF1.0 2SPD	\$2,265.40
2092136206	1HP BADU EcoM2/S90-II SF1.0 2SPD	\$1,395.81
2092136209	1HP BADU EcoM2/S90-II SF1.0 2SPD	\$1,926.48
2092156206	1.5HP BADU EcoM2/S90-III SF1.0	\$1,415.13
2092156209	1.5HP BADU EcoM2/S90-III SF1.0	\$1,966.62
2092216206	2HP BADU EcoM2/S90-IV SF1.0 2SPD	\$1,502.84
2092216209	2HP BADU EcoM2/S90-IV SF1.0 2SPD	\$2,103.38



2092136013	1HP BADU EcoM3 SF1.25 208-230V	\$1,754.05
2092136213	1HP BADU EcoM3 V - 2 MINUTES	\$1,650.00
2092136513	1HP BADU EcoM3 V w/2 HR DEFAULT	\$1,650.00



2072326213	3.5HP BADU EcoMV/72-VI SF1.0	\$3,250.94
2072326215	3.5HP BADU EcoMV/72-VI SF1.0	\$3,106.75